

Technical Report No. 54
Implementation of Quality Risk
Management For Pharmaceutical
and Biotechnology Manufacturing
Operations

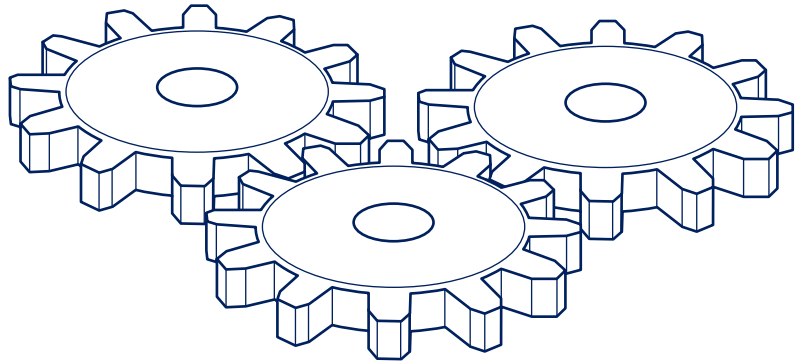

**Paradigm
Change in
Manufacturing
OperationsSM**



2012

PDA PCMOSM Technical Report 54: Implementation of Quality Risk Management for Commercial and Biotech Manufacturing Operations Task Force Members

Authors

Emabelle Ramnarine, Task Force Leader,
Genentech

Jeffrey L. Hartman, Co-Leader, Merck

Thomas Genova, Ph.D., Johnson & Johnson

Laura Huffman, United States Food and Drug
Administration

Kathy Lee, United States Food and Drug
Administration

Michael A. Long, Ph.D., ConcordiaValSource

Kevin O'Donnell, Ph.D., Irish Medicines Board

Jayesh Patel, F. Hoffmann-La Roche Inc.

Siegfried Schmitt,* Ph.D., PAREXEL Consulting

Rebecca Spohn, Amgen Inc.

Edward C. Tidswell, Ph.D., Baxter Healthcare
Corporation

Robert P. Tomaselli, Johnson & Johnson SPT

Anthony C. Warchut, PAREXEL Consulting

Other Contributors

James Agalloco, Agalloco & Associates, Inc.

James E. Akers, Akers, Kennedy and Associates

Kristen Anderson, United States Food and Drug
Administration

Veronique D. Davoust, Ph.D., Pfizer

Lance D. Goodreau, New England BioLabs

Ghada Haddad, Genentech

William Harclerode, Forest Labs

Kristin Murray, Pfizer

Stephen Reich, Pfizer

* PDA and the Task Force wants to thank Siegfried Schmitt for spending a considerable amount of time volunteering as the copy editor for this Technical Report. His effort resulted in a well-edited document and saved PDA resources it would normally have committed to a professional copy editor.

This technical report was developed as part of PDA's Paradigm Change in Manufacturing Operations (PCMO) project. The content and views expressed in this Technical Report are the result of a consensus achieved by the Task Force and are not necessarily views of the organizations they represent.

Implementation of Quality Risk Management For Pharmaceutical and Biotechnology Manufacturing Operations

PCMOSM Technical Report No. 54

ISBN: 978-0-939459-38-4

© 2012 Parenteral Drug Association, Inc.

All rights reserved.



**Paradigm
Change in
Manufacturing
OperationsSM**

Paradigm Change in Manufacturing Operations (PCMOSM)

PDA launched the project activities related to the PCMO program in December 2008 to help implement the scientific application of the ICH Q8, Q9 and Q10 series. The PDA Board of Directors approved this program in cooperation with the Regulatory Affairs and Quality Advisory Board, and the Biotechnology Advisory Board and Science Advisory Board of PDA.

Although there are a number of acceptable pathways to address this concept, the PCMO program follows and covers the drug product lifecycle, employing the strategic theme of process robustness within the framework of the manufacturing operations. This project focuses on Pharmaceutical Quality Systems as an enabler of Quality Risk Management and Knowledge Management.

Using the Parenteral Drug Association's (PDA) membership expertise, the goal of the Paradigm Change in Manufacturing Operations Project is to drive the establishment of 'best practice' documents and /or training events in order to assist pharmaceutical manufacturers of Investigational Medicinal Products (IMPs) and commercial products in implementing the ICH guidelines on Pharmaceutical Development (ICH Q8, Q11), Quality Risk Management (ICH Q9) and Pharmaceutical Quality Systems (ICH Q10).

The PCMO program facilitates communication among the experts from industry, university and regulators as well as experts from the respective ICH Expert Working Groups and Implementation Working Group. PCMO task force members also contribute to PDA conferences and workshops on the subject.

PCMO follows the product lifecycle concept and has the following strategic intent:

- Enable an innovative environment for continual improvement of products and systems
- Integrate science and technology into manufacturing practice
- Enhance manufacturing process robustness, risk based decision making and knowledge management
- Foster communication among industry and regulatory authorities

The Product Life Cycle

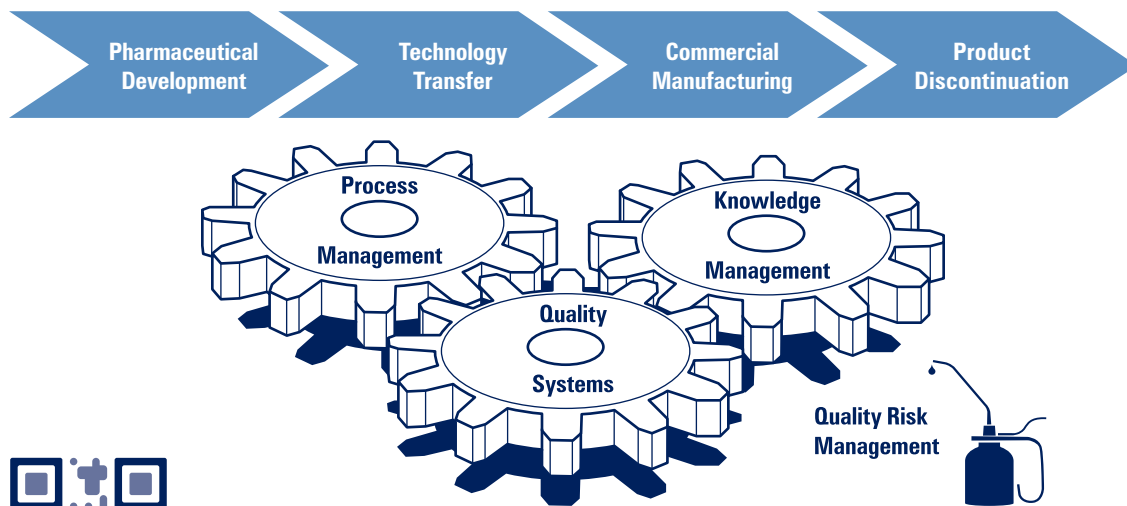

For more information, including the PCMO Dossier, and to get involved, go to www.pda.org/pcmo

Table of Contents

1.0 Introduction.....	1	4.2.3 Risk Analysis	20
1.1 Purpose and Scope.....	2	4.2.4 Risk Evaluation	21
2.0 Glossary of Terms	3	4.2.5 Supporting Tools	22
3.0 General Principles On Quality Risk Management Application	7	4.3 Risk Control	22
3.1 When, Where, and How to Apply Quality Risk Management	7	4.3.1 Risk Reduction.....	23
3.1.1 Quality Risk Management Application During Pharmaceutical Development.....	7	4.3.2 Risk Acceptance.....	24
3.1.2 Quality Risk Management Application during Technology Transfer.....	8	4.4 Output/Result of the Quality Risk Management Process	24
3.1.3 Quality Risk Management Application During Commercial Manufacturing	8	4.4.1 Risk Register	25
3.1.4 Quality Risk Management Application During Product Discontinuation	8	4.5 Risk Review	25
3.2 Proactive and Reactive Application of Quality Risk Management.....	9	4.5.1 Event-Based Reviews	25
3.3 Formality of the Quality Risk Management Process	9	4.5.1.1 Deviations or Non-Conformances	26
3.4 Establishing a Quality Risk Management Policy	10	4.5.1.2 Product Complaints, Returns, or Patient Safety Related Events.....	26
3.5 Management Commitment	10	4.5.1.3 Data Trends	26
3.6 Understanding the Organization and How it Contextualizes Risk	11	4.5.1.4 Change Control.....	26
3.7 Integration into Organizational Processes ...	11	4.5.1.5 Audits and Inspections	27
3.8 Establishing Communication and Reporting Mechanisms.....	12	4.5.2 Scheduled Reviews	27
3.9 Roles and Responsibilities	12	4.6 Risk Communication.....	27
3.10 Heuristics and Biases in Quality Risk Management	13	4.6.1 Essential Elements of Risk Communication.....	28
4.0 Implementation Of The Quality Risk Management Process	16	4.6.2 Difficulties with Risk Communication	30
4.1 Initiating a Quality Risk Management Process... ..	16	5.0 How To Use Quality Risk Management As An Enabler	31
4.2 Risk Assessment.....	16	5.1 QRM Application During Process Validation Lifecycle	31
4.2.1 Execution of Risk Assessments.....	17	5.1.1 Quality Risk Management Applied to Stage 1 Process Design.....	31
4.2.2 Risk Identification	20	5.1.2 Quality Risk Management Applied to Stage 2 Process Qualification	32
		5.1.3 Quality Risk Management Applied to Sterilization and Cleaning Validation	33
		5.1.4 Quality Risk Management Applied to Stage 3 Continued Process Verification ..	34
		5.2 QRM Application during Facilities, Manufacturing and Control Systems Lifecycle	35
		5.2.1 Lifecycle Strategy	35
		5.2.2 Quality Risk Management Application to System Qualification Activities.....	36

5.2.3 QRM Application to Facility and Equipment Operation, Maintenance and Continual Improvement	37	5.5 Quality Risk Management Application for Contract Services.....	46
5.2.4 Facility and Equipment Design: Dedicated Versus Multi-Product Facilities	38	5.5.1 Supplier Selection, Initiation and Technology Transfer	46
5.3 Quality Risk Management Application During Technology Transfer	39	5.5.2 Routine Oversight of Supplier	47
5.4 Quality Risk Management Application in Materials Management	41	5.5.3 Continual Improvement.....	48
5.4.1 Supplier Selection and Management	41	5.5.4 Supplier Decommissioning	48
5.4.2 Risk Control for Suppliers	43	5.6 Knowledge Management.....	48
5.4.3 Quality Agreements	45	6.0 Conclusions	50
		7.0 References	51

FIGURES AND TABLES INDEX

Figure 1-1 Example of a Maturity Model for QRM....	2	Figure 5.2.1-1 Systems Lifecycle	35
Figure 3.1-1 Product Lifecycle	7	Figure 5.2.2-1 Approach for QRM Application to Determine System Testing Requirements	37
Figure 3.3-1 Rigor and Formality of QRM Approaches	9	Figure 5.2.3-1 QRM Application during Operation and Maintenance Activities	38
Figure 3.3-2 Rigor and Formality Spectrum for QRM Activities	10	Figure 5.4.1-1 Supplier Assessment and Qualification Lifecycle	42
Table 3.7-1 Risk Management Maturity Level	12	Table 5.4.2.1 Example of Risk Management Application to Determine Supplier Audit Frequency	44
Table 3.10-1 Strategies to Manage Common Perception Biases	15	Figure 5.5-1 Lifecycle for Control of Contract Manufacturing Organizations.....	46
Figure 4.2-1 Identifying the Level of Rigor for a Risk Assessment	17	Table 5.5.2-1 Example of QRM Application to Ensure Sufficient CMO Oversight	47
Table 4.2-1 Comparison of Common Risk Management Tools	19		
Figure 4.2.4-1 Classifications of Risks	21		
Table 4.6.1-1 Summary of Essential Information Conveyed to Ensure an Effective and Sustainable QRM Program	29		